





Single door 280KG Electromagnetic lock



EL-600SD

Specifications

EL-600SD	LED, door sensor   
Lock size	250Lx46Wx25.5H(mm)
Armature Plate	180Lx38Wx11H(mm)
Holding Force	280kg (600Lbs)
Voltage	DC12V
Current Draw	12V/500mA
Signal Output	Dry Contact, Max Rating of Contact Current 3A
Surface Temp	≤20°C
Operating Temp	-10°C ~ 55°C (14°F~131°F)
Suitable Humidity	0~90%(non-condensing)
Finishes for Shell	Anodized aluminum surface texture processing
Finishes for Magnetic	Zinc
Finishes for Armature	Zinc
Weight	2kg
Standard Packing	10pcs

Dimensions

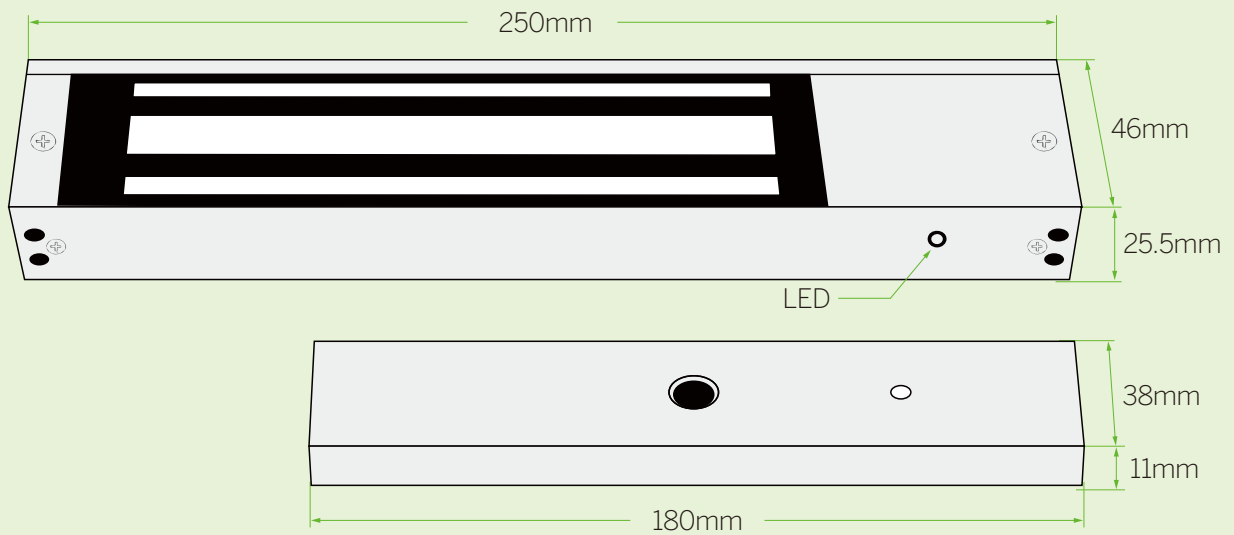

Wiring diagram

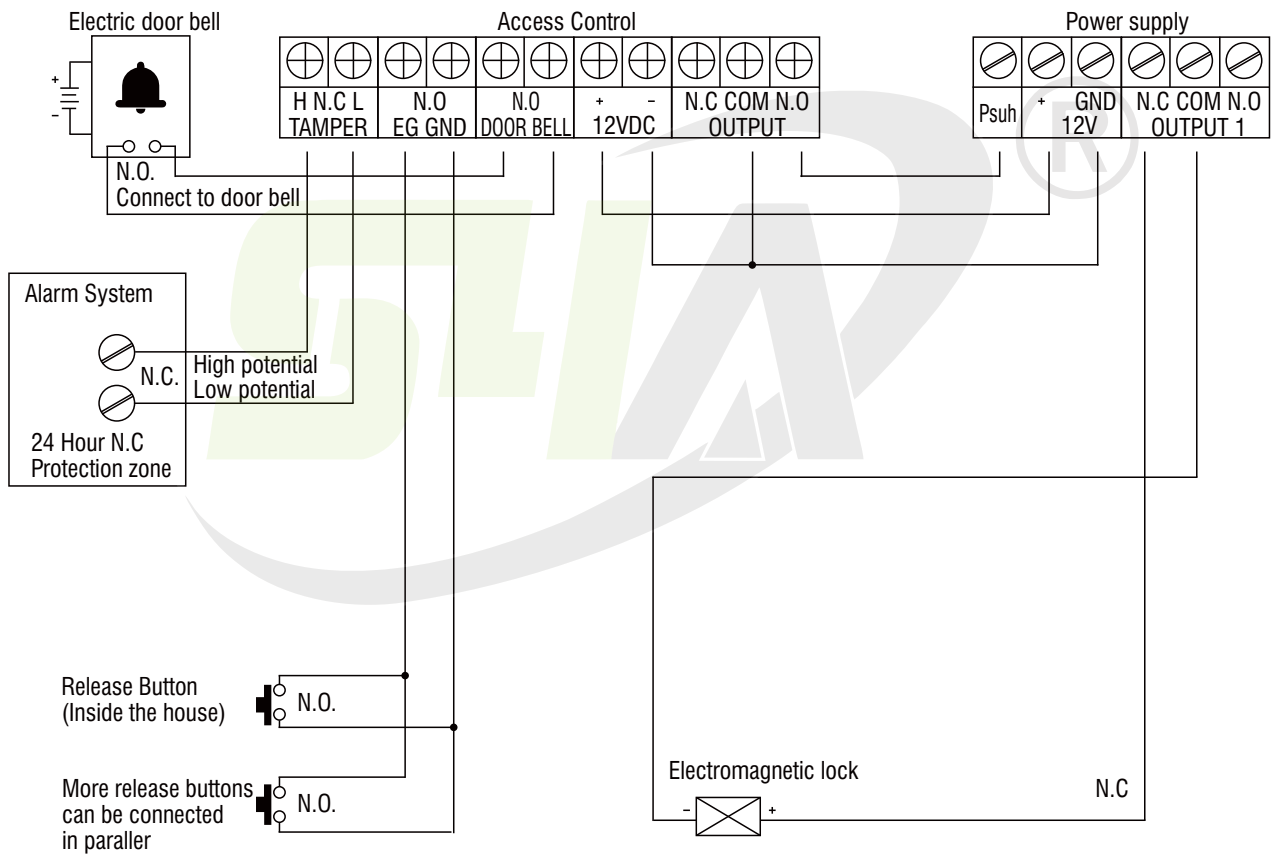

S4A Industrial Co., Limited

Address: 6th Floor, Haotai Industrial Zone, Minzhi road,
Longhua District, Shenzhen. CN 518131

Tel: +86 755 29450011

www.s4a-access.com / Email: sales@s4a-access.com
Mob/Whatsapp/Wechat/Viber: +86 134 1050 0721